

Exclusively for distribution in the EAME territory



Generator Set Pictured May Include Optional Accessories

SOUND ATTENUATED ENCLOSURES

500 - 550 kVA, 50 Hz

The sound attenuated enclosures for the range of Perkins powered GEP500 to GEP550 generator sets are a result of continuing research and development by our acoustic engineer specialists. These enclosures reduce sound levels to comply with the new European Community regulations 2000/14/EC which became effective on 1 January 2002.

The fully weatherproof enclosures incorporate internally mounted exhaust silencers and are of extremely rugged construction in order to withstand the rough handling common on many construction sites. They are designed on modular principles with many interchangeable components permitting on-site repair.

FEATURES

ROBUST/HIGHLY CORROSION RESISTANT CONSTRUCTION

- Black finish stainless steel locks and hinges
- Zinc plated or stainless steel fasteners
- Body made from steel components treated with polyester powder coating

EXCELLENT ACCESS FOR MAINTENANCE

- Two large doors on each side
- Radiator fill access plate
- Lube oil and cooling water drains piped to exterior of the enclosure

SECURITY AND SAFETY

- Control panel viewing window in a lockable access door
- Emergency stop push button (red) mounted on enclosure exterior
- Cooling fan and battery charging alternator fully guarded
- Fuel fill and battery can only be reached via lockable access doors
- Exhaust silencing system totally enclosed for operator safety

TRANSPORTABILITY

- Tested and certified single point lifting facility
- Lifting points on baseframe

OPTIONS

- Oil field type skid with dragging points and fork lift truck pockets

Exclusively from your Caterpillar® dealer

SOUND PRESSURE LEVELS (dBA)

Generator Set Model	Duty	50 Hz at 1500 rpm						
		Sound Power Level (LWA)	15 m		7 m		1 m	
			75% Load	100% Load	75% Load	100% Load	75% Load	100% Load
GEP500	Prime	99	64.5	65.6	70.5	71.6	79.4	80.2
	Standby	99	64.5	65.6	70.5	71.6	79.4	80.2
GEP550	Prime	99	64.5	65.6	70.5	71.6	79.4	80.7
	Standby	99	64.5	66.5	70.5	72.5	79.4	80.2

Levels in accordance with European Noise Directive (2000/14/EC)

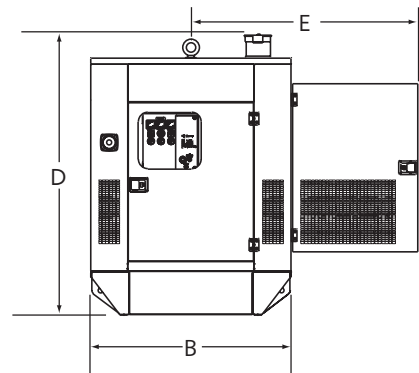
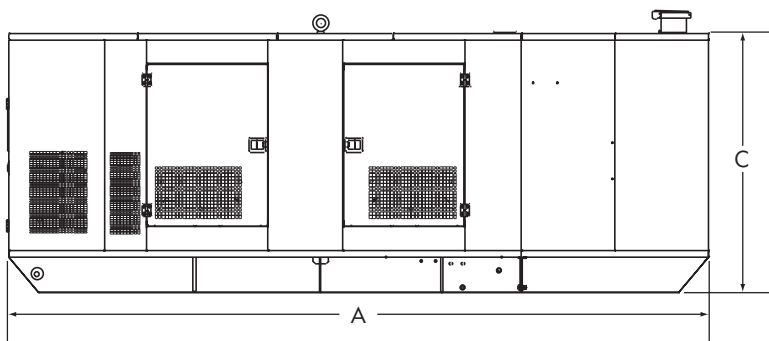

DIMENSIONS AND WEIGHTS

Generator Set Model	A mm (in)	B mm (in)	C mm (in)	D mm (in)	E mm (in)*	Fuel Capacity L (US Gal)	Weight kgs kg (lb)
GEP500	5823 (229.3)	1600 (63.0)	2150 (84.6)	2346 (92.4)	1810 (71.3)	880 (232.5)	5444 (12004)
GEP550	5823 (229.3)	1600 (63.0)	2150 (84.6)	2346 (92.4)	1810 (71.3)	880 (232.5)	5454 (12026)

Weight includes lube oil. Dimensions in mm.

*Clearance required on both sides.

www.CAT-ElectricPower.com

© 2003 Caterpillar
All rights reserved.
Printed in U.S.A.

European sourced

LEHF3133 (08/03)

Materials and specifications are subject to change without notice.
The International System of Units (SI) is used in this publication.