

*Exclusively from your Caterpillar® dealer*



## SOUND ATTENUATED ENCLOSURES

26-165 kVA, 50 Hz

34-165 kVA, 60 Hz

The fully weatherproof Sound Attenuated (SA) enclosures reduce sound levels to a level that is lower than European Community regulations.

The enclosures incorporate internally mounted exhaust silencers and are of extremely rugged construction to withstand the rough handling common on many construction sites. They are designed on modular principles with many interchangeable components permitting on-site repair.

Enclosure pictured may include optional accessories

### FEATURES

#### ROBUST/HIGHLY CORROSION RESISTANT CONSTRUCTION

- Stainless steel locks and hinges
- Zinc plated or stainless steel fasteners
- Body made from steel components treated with polyester powder coating

#### EXCELLENT ACCESS FOR MAINTENANCE

- Full length extra wide doors on each side
- Doors top hung and supported by gas struts
- Radiator fill access plate
- Lube oil and cooling water drains piped to exterior of the enclosure

#### SECURITY AND SAFETY

- Control panel viewing window in a lockable access-door
- Emergency stop button mounted on enclosure-exterior
- Cooling fan and battery charging alternator fully guarded
- Fuel fill and battery can only be reached via lockable access doors
- Exhaust silencing system totally enclosed for operator-safety

#### TRANSPORTABILITY

- Tested and certified single point lifting facility
- Lifting points on baseframe

#### OPTIONAL FEATURE

- Oil field type skid with dragging points and fork lift truck pockets



Exclusively from your Caterpillar® dealer

## SOUND PRESSURE LEVELS (dBA)

Generator Set Model	Duty	Sound Power Level (LWA)	50 Hz at 1500 rpm						60 Hz at 1800 rpm					
			15 m		7 m		1 m		15 m		7 m		1 m	
			75% Load	100% Load	75% Load	100% Load	75% Load	100% Load	75% Load	100% Load	75% Load	100% Load	75% Load	100% Load
GEP65-2	Prime	97	60.5	60.9	66.5	66.9	77.5	77.7	-	-	-	-	-	-
	Standby	97	60.6	61.1	66.6	67.1	77.6	77.8	-	-	-	-	-	-
GEP80SP1	Prime	97	62.6	63.2	68.6	69.2	80.3	80.9	65.5	67.0	72.0	73.0	82.0	84.0
	Standby	97	62.8	63.5	78.8	69.5	80.5	81.1	65.5	67.0	72.0	73.0	82.0	84.0
GEP80SP2	Prime	97	62.8	63.4	68.8	69.4	79.9	80.4	-	-	-	-	-	-
	Standby	97	63.0	63.7	69.0	69.7	80.0	80.7	-	-	-	-	-	-
GEP88-1	Prime	96	63.4	64.5	69.4	70.5	80.0	81.4	66.7	68.2	72.7	74.2	83.0	84.8
	Standby	96	63.6	65.1	69.6	71.1	80.4	82.1	67.1	69.0	73.1	75.0	83.5	85.8
GEP88-2	Prime	97	62.6	63.1	68.6	69.1	79.8	80.1	-	-	-	-	-	-
	Standby	97	62.7	63.3	68.7	69.3	79.9	80.3	-	-	-	-	-	-
GEP88SP1	Prime	97	63.5	64.9	65.6	70.9	71.6	82.2	82.9	67.0	72.0	73.0	82.0	84.0
	Standby	97	63.5	64.9	65.6	70.9	71.6	82.2	82.9	67.0	72.0	73.0	82.0	84.0
GEP100	Prime	97	62.6	63.2	68.6	69.2	80.3	80.9	65.5	67.0	72.0	73.0	82.0	84.0
	Standby	97	62.8	63.5	68.8	69.5	80.5	81.1	65.5	67.0	72.0	73.0	82.0	84.0
GEP105SP1	Prime	96	62.4	62.9	68.4	68.9	80.0	80.1	62.2	66.7	72.2	72.7	83.9	84.3
	Standby	96	62.6	63.1	68.6	69.1	80.0	80.1	66.4	66.8	72.4	72.8	84.0	84.4
GEP110	Prime	97	62.8	63.5	68.8	69.5	80.5	81.1	65.5	67.0	72.0	73.0	82.0	84.0
	Standby	97	63.0	63.8	69.0	69.8	80.7	81.3	65.5	67.0	72.0	73.0	82.0	84.0
GEP110-2	Prime	97	63.0	63.7	69.0	69.7	80.0	80.7	-	-	-	-	-	-
	Standby	97	63.2	64.1	69.2	70.1	80.2	81.0	-	-	-	-	-	-
GEP150	Prime	96	62.6	63.1	68.6	69.1	80.0	80.1	66.6	67.1	72.6	73.1	84.2	84.7
	Standby	96	62.8	63.3	68.8	69.3	80.1	80.0	66.7	67.2	72.7	73.2	84.3	84.9
GEP165	Prime	96	62.8	63.5	68.8	69.5	79.8	80.6	-	-	-	-	-	-
	Standby	96	63.1	63.8	69.1	69.8	80.0	80.9	-	-	-	-	-	-

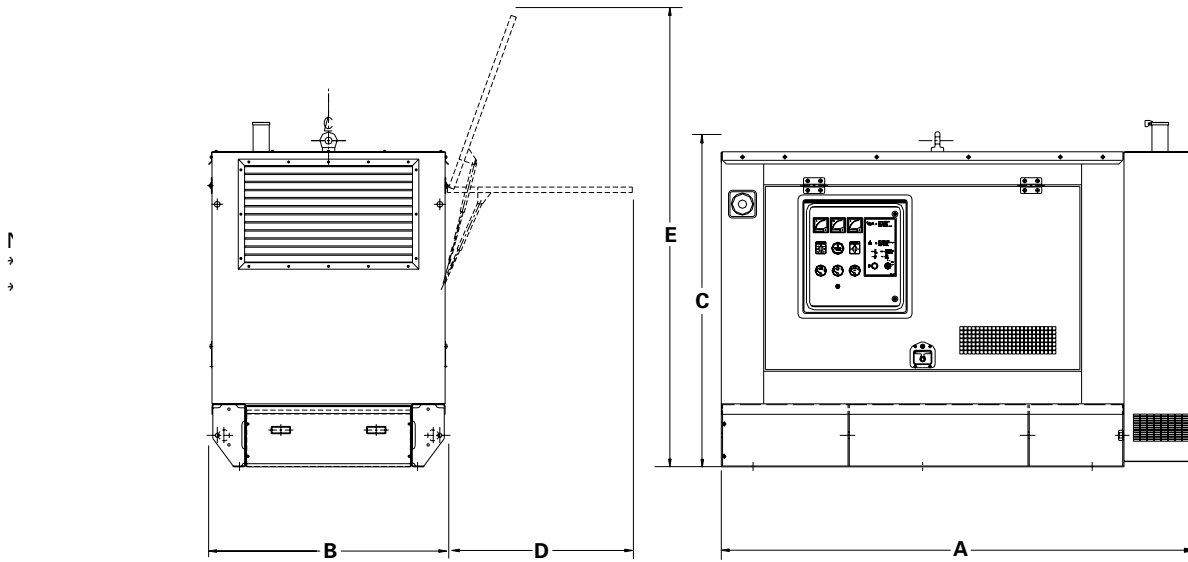

## DIMENSIONS AND WEIGHTS

Generator Set Model	A: mm (in)	B: mm (in)	C: mm (in)	*D: mm (in)	E: mm (in)	Fuel Capacity: l (US gal)	Weight: kg (lb)
GEP30-1	2090 (82.3)	950 (37.4)	1558 (61.3)	880 (34.6)	2010 (79.1)	230 (61.0)	1104 (2434)
GEP30-2	2090 (82.3)	950 (37.4)	1558 (61.3)	880 (34.6)	2010 (79.1)	230 (61.0)	1104 (2434)
GEP33-1	2090 (82.3)	950 (37.4)	1558 (61.3)	880 (34.6)	2010 (79.1)	230 (61.0)	1114 (2456)
GEP33-2	2090 (82.3)	950 (37.4)	1558 (61.3)	880 (34.6)	2010 (79.1)	230 (61.0)	1114 (2456)
GEP44-2	2290 (90.2)	1100 (43.3)	1500 (59.1)	880 (34.6)	2080 (81.9)	245 (65.0)	1245 (2745)
GEP44-5	2242 (88.3)	1100 (43.3)	1640 (64.6)	880 (34.6)	2080 (81.9)	245 (65.0)	1245 (2745)
GEP50-2	2290 (90.2)	1100 (43.3)	1640 (64.6)	880 (34.6)	2080 (81.9)	245 (65.0)	1245 (2745)
GEP50-5	2242 (88.3)	1100 (43.3)	1640 (64.6)	880 (34.6)	2080 (81.9)	245 (65.0)	1245 (2745)
GEP55-1	2242 (88.3)	1100 (43.3)	1640 (64.6)	880 (34.6)	2080 (81.9)	245 (65.0)	1265 (2789)
GEP55-2	2290 (90.2)	1100 (43.3)	1640 (64.6)	880 (34.6)	2080 (81.9)	245 (65.0)	1265 (2789)
GEP65-2	2290 (90.2)	1100 (43.3)	1640 (64.6)	880 (34.6)	2080 (81.9)	245 (65.0)	1315 (2899)
GEP65-5	2242 (88.3)	1100 (43.3)	1640 (64.6)	880 (34.6)	2080 (81.9)	245 (65.0)	1315 (2899)
GEP88-1	2242 (88.3)	1100 (43.3)	1640 (64.6)	880 (34.6)	2080 (81.9)	245 (65.0)	1435 (3164)
GEP88-2	2290 (90.2)	1100 (43.3)	1640 (64.6)	880 (34.6)	2080 (81.9)	245 (65.0)	1435 (3164)
GEP100	2805 (110.4)	1100 (43.3)	1610 (63.4)	885 (34.8)	2030 (79.9)	300 (79.0)	1694 (3735)
GEP110	2805 (110.4)	1100 (43.3)	1610 (63.4)	885 (34.8)	2030 (79.9)	300 (79.0)	1714 (3779)
GEP110-2	2805 (110.4)	1100 (43.3)	1610 (63.4)	885 (34.8)	2030 (79.9)	300 (79.0)	1714 (3779)
GEP150	3425 (134.8)	1100 (43.3)	1590 (62.6)	885 (34.8)	2099 (82.6)	375 (99.0)	1970 (4343)
GEP165	3425 (134.8)	1100 (43.3)	1790 (70.5)	885 (34.8)	2099 (82.6)	375 (99.0)	1975 (4354)

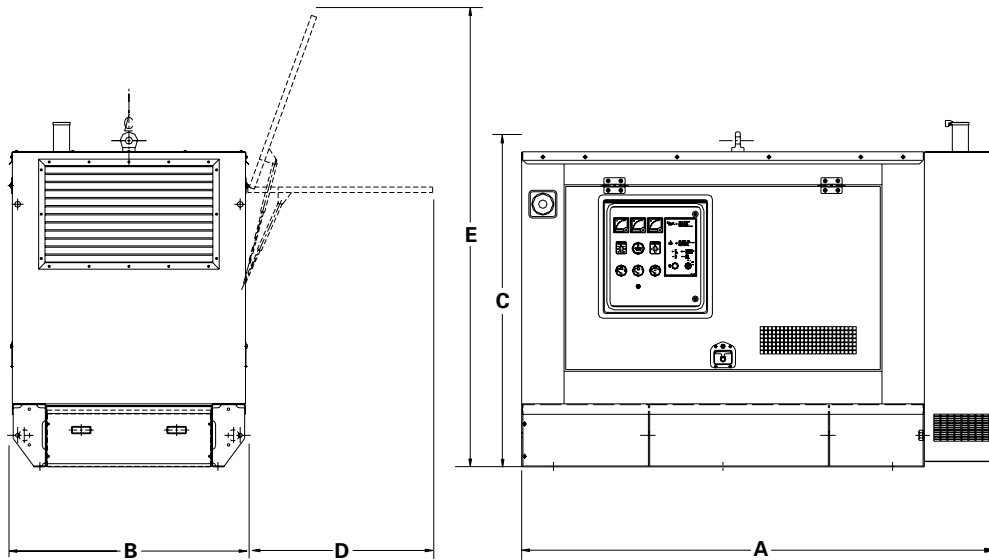

## DIMENSIONS AND WEIGHTS

Generator Set Model	A: mm (in)	B: mm (in)	C: mm (in)	*D: mm (in)	E: mm (in)	Fuel Capacity: l (US gal)	Weight: kg (lb)
GEP26SP1	2090 (82.3)	950 (37.4)	1558 (61.3)	880 (34.6)	2010 (79.1)	230 (61.0)	1114 (2456)
GEP26SP2	2090 (82.3)	950 (37.4)	1558 (61.3)	880 (34.6)	2010 (79.1)	230 (61.0)	1114 (2456)
GEP35SP2	2090 (82.3)	1100 (43.3)	1640 (64.6)	880 (34.6)	2080 (81.9)	245 (65.0)	1315 (2899)
GEP35SP5	2090 (82.3)	1100 (43.3)	1640 (64.6)	880 (34.6)	2080 (81.9)	245 (65.0)	1315 (2899)
GEP44SP1	2242 (88.3)	1100 (43.3)	1640 (64.6)	880 (34.6)	2080 (81.9)	245 (65.0)	1315 (2899)
GEP44SP2	2242 (88.3)	1100 (43.3)	1640 (64.6)	880 (34.6)	2080 (81.9)	245 (65.0)	1315 (2899)
GEP50SP2	2242 (88.3)	1100 (43.3)	1640 (64.6)	880 (34.6)	2080 (81.9)	245 (65.0)	1355 (2987)
GEP50SP5	2242 (88.3)	1100 (43.3)	1640 (64.6)	880 (34.6)	2080 (81.9)	245 (65.0)	1355 (2987)
GEP64SP1	2242 (88.3)	1100 (43.3)	1640 (64.6)	880 (34.6)	2080 (81.9)	245 (65.0)	1478 (3258)
GEP64SP2	2242 (88.3)	1100 (43.3)	1640 (64.6)	880 (34.6)	2080 (81.9)	245 (65.0)	1478 (3258)
GEP80SP1	2805 (110.4)	1100 (43.3)	1610 (63.4)	885 (34.8)	2030 (79.9)	300 (79.2)	1839 (4054)
GEP80SP2	2805 (110.4)	1100 (43.3)	1610 (63.4)	885 (34.8)	2030 (79.9)	300 (79.2)	1839 (4054)
GEP88SP1	3900 (153.5)	1300 (51.2)	1996 (78.6)	950 (37.4)	N/A**	550 (145)	2907 (6409)
GEP105SP1	3900 (154)	1300 (51.2)	1996 (78.6)	950 (37.4)	N/A**	550 (145)	2907 (6409)

Net weight with lube oil, no coolant, no fuel.

\* Clearance required both sides

\*\* Side opening doors